

## G80 Swivel Hoist Ring

Model	W.L.L. t	A mm	B mm	C mm	D mm	K mm	L mm	M mm	S mm	SW mm	Ø mm	Torque Nm	Weight kgs
<b>M8</b>	0.3	8	52.5	35	30	11	46	55	6	13	14	10-15	0.36
<b>M10</b>	0.63	10	52.5	35	30	16	52	55	6	17	14	10-15	0.38
<b>M12</b>	1	12	54	40	36	18	62	68	8	19	18	10-15	0.71
<b>M14</b>	1.2	14	54	40	36	21	66	68	8	22	18	20-30	0.72
<b>M16</b>	1.5	16	54	40	36	24	70	68	8	24	18	20-30	0.74
<b>M20</b>	2.5	20	80	54	50	30	88	83	12	30	16	50-70	1.19
<b>M24</b>	4	24	94	54	50	36	100	83	14	36	18	130-160	1.38
<b>M27</b>	4	27	106	73	68	38	120	120	17	41	27	180-220	4.18
<b>M30</b>	5	30	106	73	68	48	132	120	17	41	27	200-250	4.4
<b>M36</b>	8	36	140.5	94	86	62	163	156	22	55	31	280-400	7.6
<b>M42</b>	15	42	155	104	95	74	194	176	24	65	40	500-600	12.4
<b>M48</b>	20	48	155	104	95	74	194	176	27	75	40	500-650	20

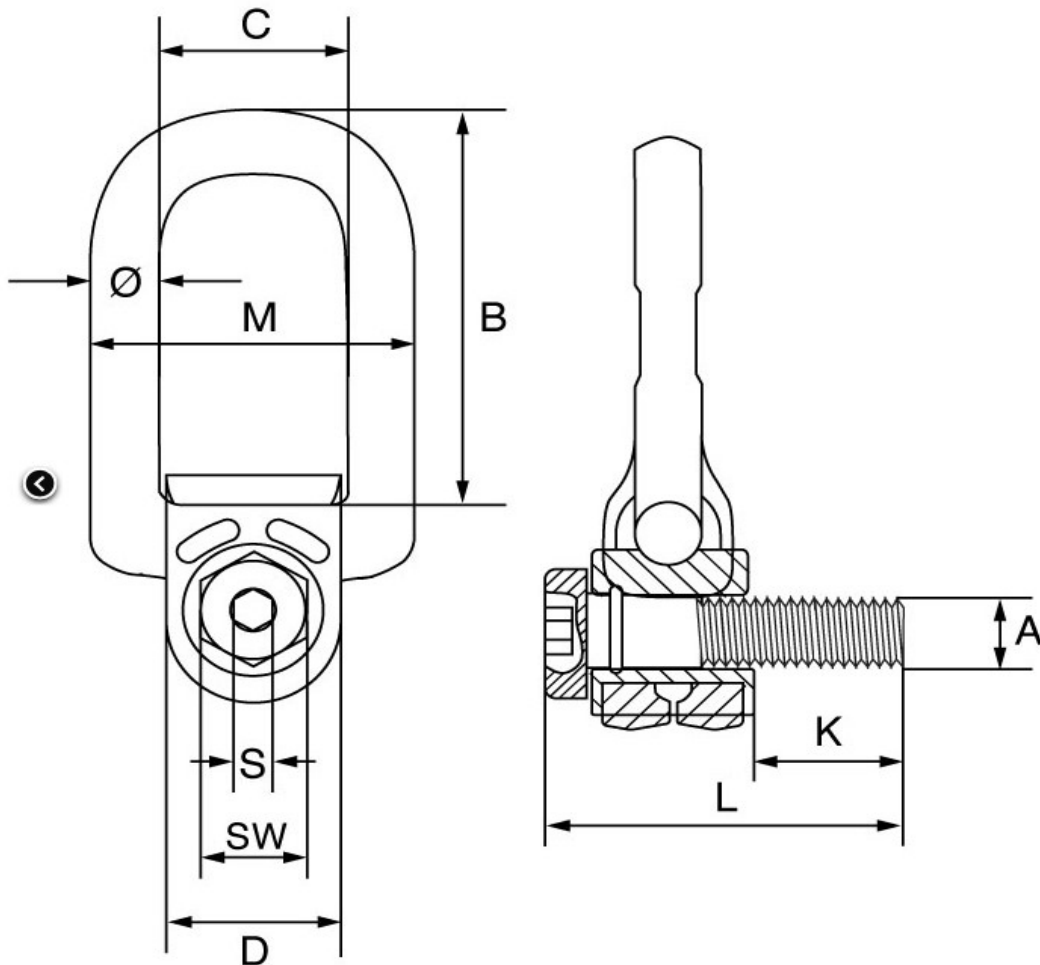



Leg	1	1	2	2	2		3 or 4		3 or 4
Angle	0°	90°	0°	90°	0-45°	45-60°	0-45°	45-60°	Assim
Factor	1	1	2	2	1.4	1	2.1	1.5	1
M8	0.3	0.3	0.6	0.6	0.42	0.3	0.63	0.45	0.3
M10	0.63	0.63	1.26	1.26	0.88	0.63	1.32	0.95	0.63
M12	1	1	2	2	1.4	1	2.1	1.5	1
M14	1.2	1.2	2.4	2.4	1.68	1.2	2.52	1.8	1.2
M16	1.5	1.5	3	3	2.1	1.5	3.15	2.25	1.5
M18	2	2	4	4	2.8	2	4.2	3	2
M20	2.5	2.5	5	5	3.5	2.5	5.25	3.75	2.5
M24	4	4	8	8	5.6	4	8.4	6	4
M27	4	4	8	8	5.6	4	8.4	6	4
M30	5	5	10	10	7	5	10.5	7.5	5
M36	8	8	16	16	11.2	8	16.8	12	8
M42	15	15	30	30	21	15	31.5	22.5	15
M48	20	20	40	40	28	20	42	30	20