

Delta DEH Electric Hoist Specifications

Model	Capacity	Lifting Speed m/min	Load Chain Øxmm	Chain Falls	Power Output	Net Weight	Extra chain weight
DEH 250	250kg	8/2	4 x 12	1	0.4/0.1kW	22kg	0.4kg kg/m
DEH 500	500kg	8/2	5 x 15	1	0.72/0.18kW	33kg	0.7kg kg/m
DEH1000	1000kg	8/2	7.1 x 21	1	1.6/0.4kW	56kg	1.1kg kg/m
DEH 2000	2000kg	4/1	7.1 x 21	2	1.6/0.4kW	58kg	2.2kg kg/m

Technical Data

Operating Voltage	400-440V / 50Hz / 3Ph
Lifting Speed	Double speed
Control Pendant Cable	Standard 6 meter
Power Cable	1 meter without plug
Load Chain	Load chain according to EN 818-7-DAT/DT
Housing Protection	IP55
Control Pendant Protection	IP65
Classification	M5/2m(ISO/FEM)
Duty Cycle/starts per hour	40% / 240
Insulation Class	F
Operating Temperature	-10C - +40C

Load Type	Goods. Not for lifting people.
Safety Devices	
Control Switch	24V pendant control with emergency stop button
Overload Protection	Externally adjustable slip clutch
Brake	Electro-magnetic spring pressure brake to hold load even if power fails.
Limit Switch	Electro-mechanical upper and lower limit switches
Thermal Protection	Protected through heat sensor

Dimensions

Model	A	B	C	D	E	F	H	J	K
DEH250	211	228	115	57	114	123	420	40	23
DEH500	231	204	165	62	118	162	465	40	27
DEH1000	264	245	175	67	128	187	575	45	31
DEH2000	264	245	175	89	150	165	690	53	38

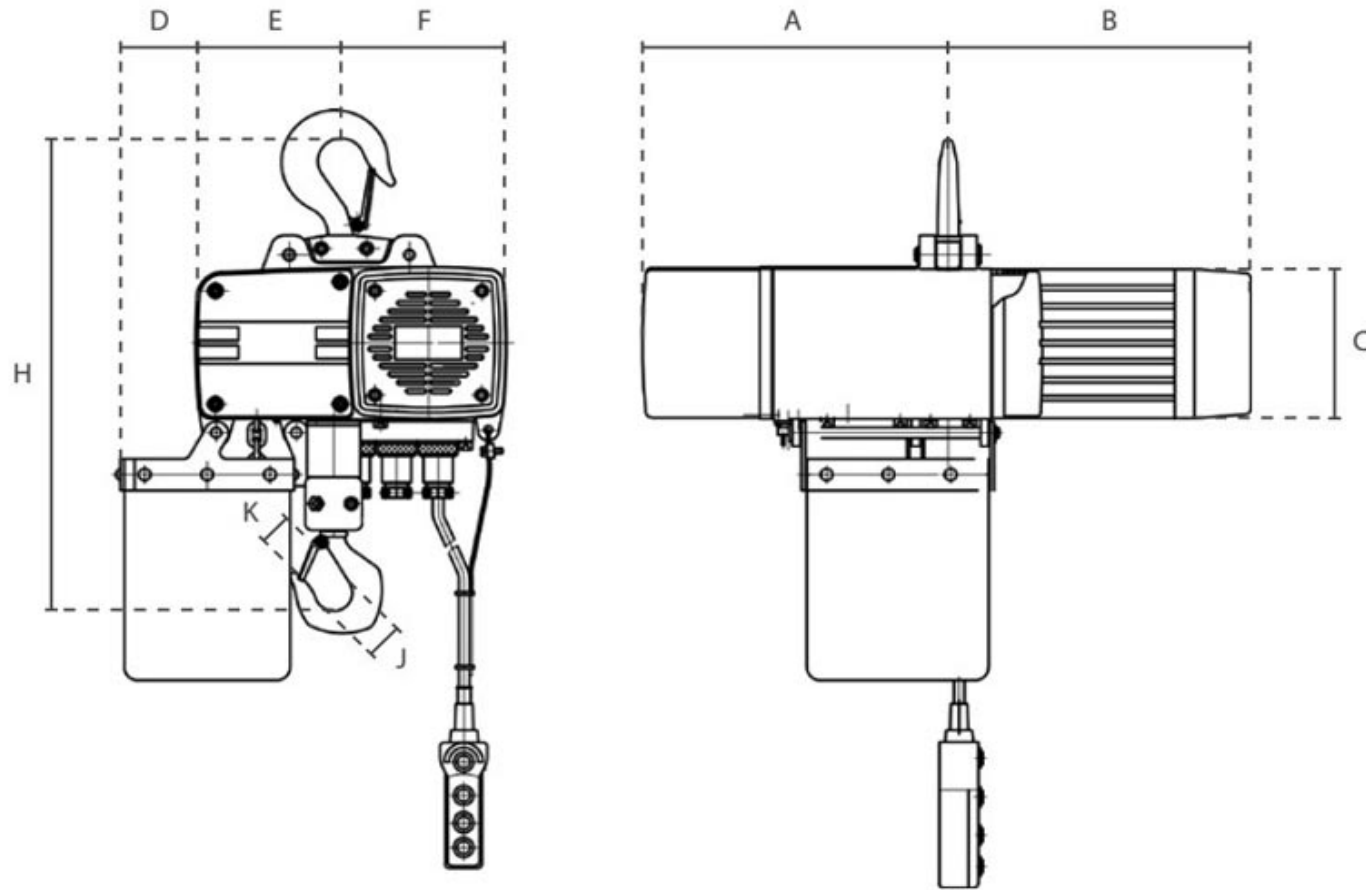

Delta DEH Trolley Specifications

Push Travel Trolley Specifications

Code	Capacity	Beam Width	Net Weight	Min. Height
DEY250	250kg	74 – 300	29kg	438mm
DEY500	500kg	74 – 300	40kg	480mm
DEY1000	1000kg	74 – 300	63kg	578mm

DEY2000	2000kg	74 – 300	70kg	670mm
---------	--------	----------	------	-------

Electric Power Trolley Specifications						
Code	Capacity	Traversing Speed	Power Output	Beam Width	Net Weight	Min. Height
DED250	250kg	20 / 6.7 m/min	0.2 / 0.07kW	74 – 300	55kg	438mm
DED500	500kg	20 / 6.7 m/min	0.2 / 0.07kW	74 – 300	66kg	480mm
DED1000	1000kg	20 / 6.7 m/min	0.2 / 0.07kW	74 – 300	89kg	578mm
DED2000	2000kg	20 / 6.7 m/min	0.4 / 0.13kW	74 – 300	98kg	670mm

Trolley Dimensions

DEY Push Trolley Dimensions for DEH Hoist							
Model	Capacity	Min. Radius	Wheel Diameter	Net Weight	A	B	C
DEY250	250kg	2.5m	68mm	7kg	424	75	270
DEY500	500kg	2.5m	68mm	7kg	424	75	270
DEY1000	1000kg	2.5m	68mm	7kg	424	75	270
DEY2000	2000kg	2.5m	75mm	12kg	424	75	270

DED Power Travel Trolley for DEH hoist								
Model	Capacity	Min. Radius	Wheel Diameter	Net Weight	A	B	C	D
DED250	250kg	2.5m	68mm	33kg	336mm	131mm	97mm	320mm
DED500	500kg	2.5m	68mm	33kg	336mm	131mm	97mm	320mm
DED1000	1000kg	2.5m	68mm	33kg	336mm	131mm	97mm	340mm

DED2000	2000kg	2.5m	75mm	40kg	338mm	132mm	113mm	340mm
---------	--------	------	------	------	-------	-------	-------	-------

